

# ACROSS

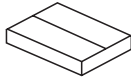

10min



x1



x1

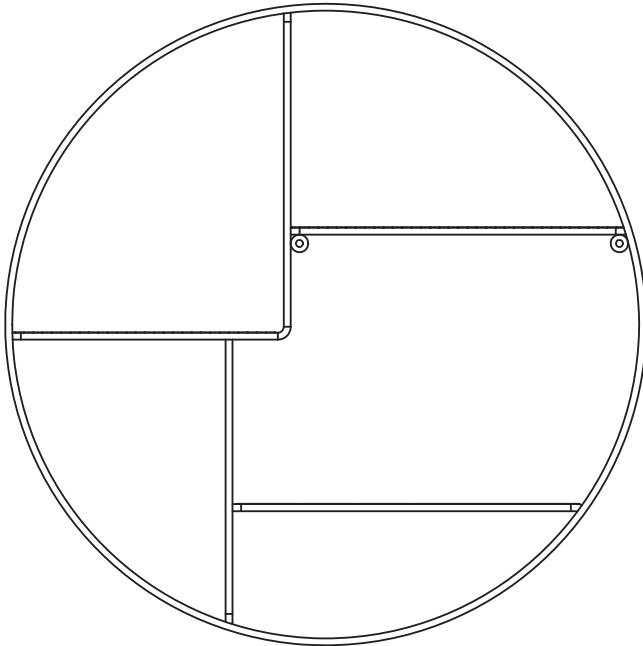

x1

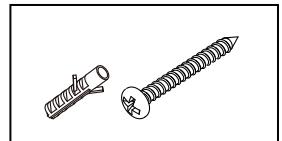

x 2

1

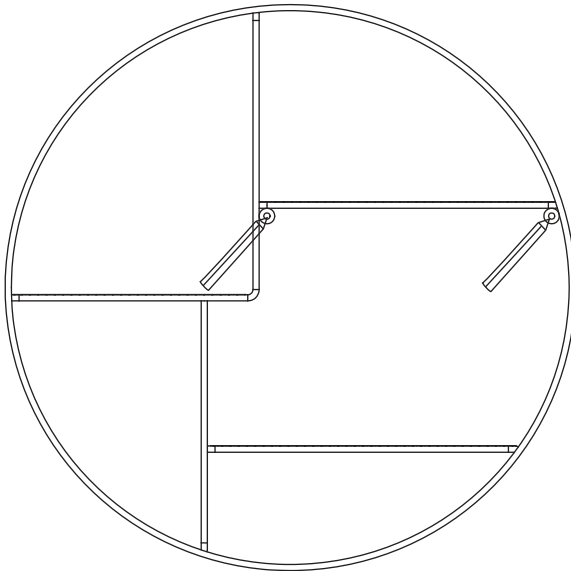

2

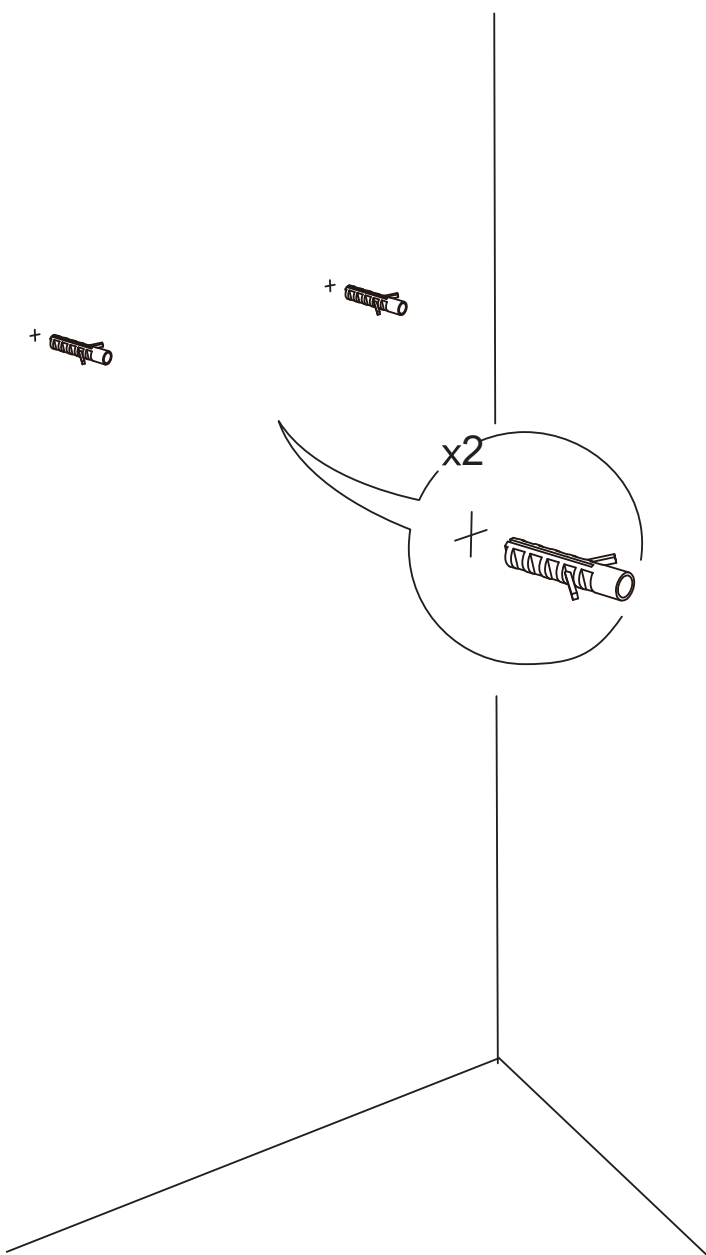

3

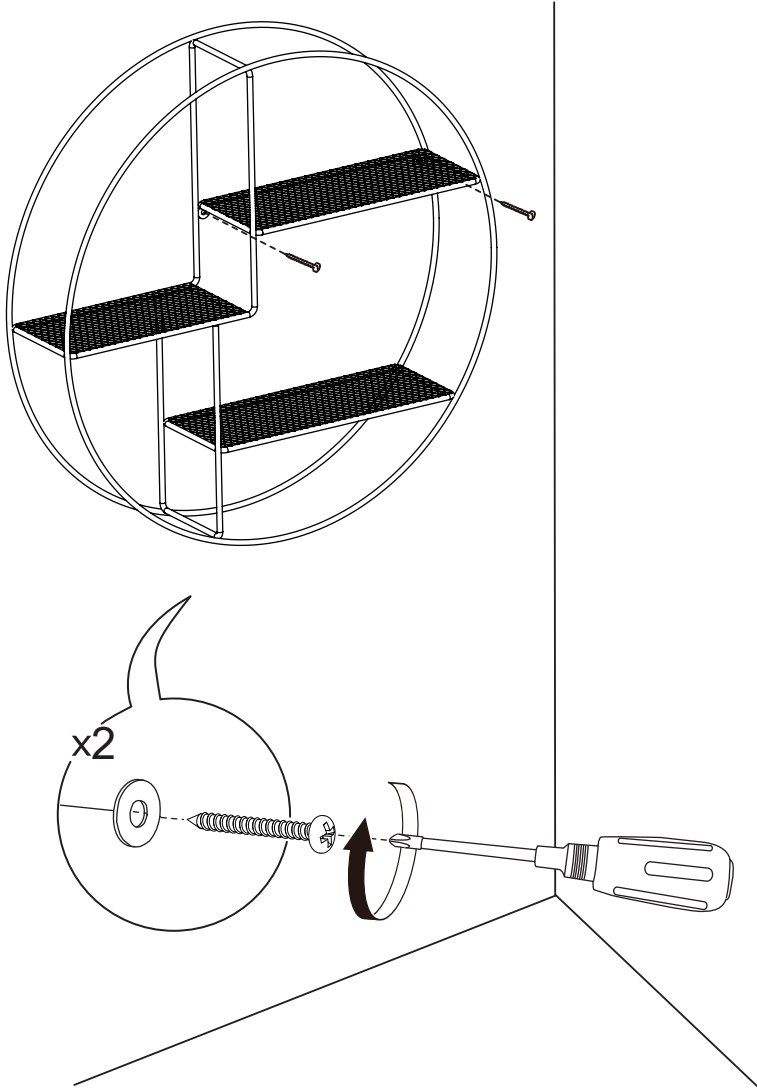
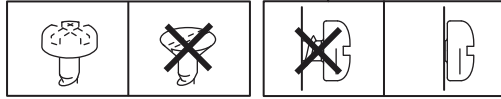



**THAT'S ALL FOLKS!**

Share your style!

**#KaveHome**

